

Specifications

Output Power HP (kW)	25 (18.5)
Phase	3 Phase
Pole	6 Pole
Frame Number	180L

Degrees of Protection	IP 55
Enclosure Construction	Totally-enclosed Fan-cooled
Thermal Class	Class F (155 °C)

Alignment	Vertical
Frame Material	Steel plate

Power Transmission	Direct-couple or Belt Driven
Direction of Rotation	Counterclockwise (CCW) viewed from shaft-end side



Connection Type	Terminal Block (6 Leads)
Coating Colour	Munsell N5.5 (Gray)
Conformed Standard	IEC 60034-1 & JEC-2137-2000



Voltage & Frequency	HT Type
	380~415V 50Hz
	380~440V 60Hz (suitable for γ - Δ starting)

Dimensions (mm)

Flange Number	Motor								
	D	IE	LA	LB	LC	LE	LG	LL	LZ
FF350	376	247	350	300 j6	400	5	20	614	18.5

Terminal Box			Shaft End						
KD	KG	KL	LR	Q	QK	S	T	U	W
PF 1 1/2	195	284	110	110	90	55 m6	10	6	16

Bearing No.		Approximated Weight (kg)	Approximated Packing Dimensions (LxWxH)	Gross Weight (kg)
Drive End	Opposite			
6312ZZ	6310ZZ	225	892 x 652 x 610	252

Connection & Connection Diagram

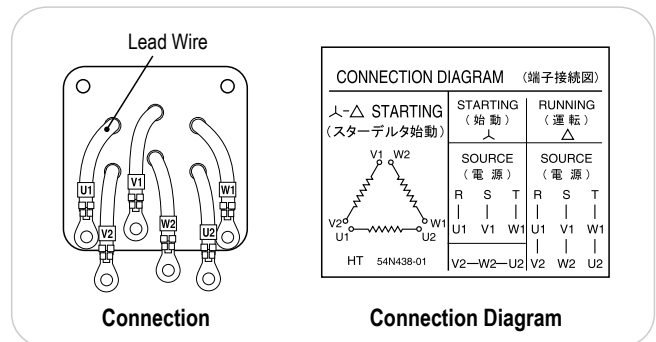

Circumstance Conditions

Ambient Temperature	-20 ~ +40°C
Ambient Humidity	95% RH or less
Operating Altitude	Less than 1,000m above sea level
Environment	No bursting / erosive gas or vapor

Motor Characteristics

Type	Hz	V	50% Load			75% Load			100% Load				Torque(%)		Is (A)	Inertia GD ² (kg-m ²)	
			(A)	Eff(%)	PF(%)	(A)	Eff(%)	PF(%)	(A)	Eff(%)	PF(%)	Speed (r/min)	Torque (kg-m)	Ts			Tm
HT	50	380	21.7	0.90	0.72	28.8	0.90	0.81	37.1	0.90	0.84	960	18.8	240	213	218	1.27
		415	22.3	0.90	0.64	28.2	0.91	0.75	35.2	0.91	0.80	970	18.6	290	254	238	
	60	380	19.9	0.91	0.78	27.6	0.91	0.84	36.5	0.90	0.86	1150	15.7	208	184	191	
		440	19.5	0.91	0.68	25.3	0.92	0.78	32.1	0.92	0.82	1170	15.4	284	249	221	